

Data sheet

Connection line M12, D-coded, 1.0 m
M12 plug straight - M12 plug straight
drag chain suitable, 4-pole, green

Page 1/6

P/N
142M1D11010
 EAN 4250184139447
 2019/01/08

Illustrations



Dimensional drawing

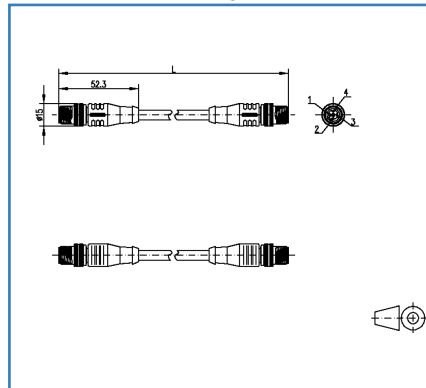

Wiring

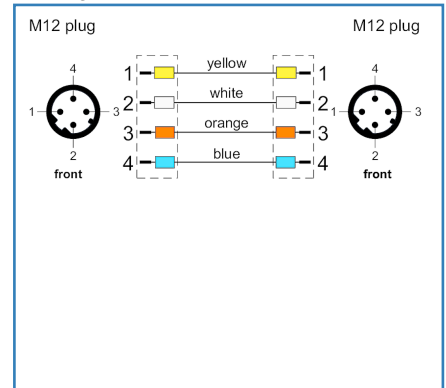

See enlarged drawings at the end of document

Product specification

- shielded M12 Ethernet connection line
- drag chain suitable
- Cat.5e, 4-pole, D-coded to IEC 61076-2-101
- side 1: M12-plug, straight
- side 2: M12-plug, straight
- extrusion-coated cable on M12 connectors
- 2x2xAWG22/7, tinned with plastic foil
- inner sheath FRNC, aluminum-coated plastic foil
- overall shield: tinned copper braid, approx. 85% covered
- Profinet (WS-GE-BL-OR) wiring
- green cable, PUR
- standard variants: 1.0 m, 2.0 m, 5.0 m, 10.0 m
- other cable lengths on request



Data sheet

Page 2/6

Connection line M12, D-coded, 1.0 m M12 plug straight - M12 plug straight drag chain suitable, 4-pole, green

P/N
142M1D11010
EAN 4250184139447
2019/01/08

Technical Data

General Data

Fields of application	Industrial Ethernet
Design	Ethernet-Connection line
Shielding	shielded
Transmission technology	Copper
Number of twisting elements	2
Twisting element	Pair
Color coding fiber/ wire(s)	yellow, white, orange, blue
Color	green
Dimensions	
Dimension - Interface 1	52.3 mm x 15 mm x 15 mm
Dimension - Interface 1	2.059 in. x 0.591 in. x 0.591 in.
Dimension - Interface 2	52.3 mm x 15 mm x 15 mm
Dimension - Interface 2	2.059 in. x 0.591 in. x 0.591 in.
Cable length (m)	1 m
Cable length (ft)	3.28 ft
Labeling option	identification label carrier

Transmission characteristics

Transmission rate up to 100 MBit (Fast Ethernet)	IEEE 802.3u
--	-------------

Connections/interfaces

Connector technology interface 1	M12-plug
Connector technology interface 2	M12-plug
Coding interface 1	D-coded
Coding interface 2	D-coded
Number of positions/contacts interface 1	4
Number of positions/contacts interface 2	4
Termination data, stranded wire (min. - max.)	
Conductor cross section, stranded wire	22/7
Conductor diameter, stranded wire (bare copper)	0.75 mm
Conductor diameter, stranded wire (bare copper)	0.03 in.



Connection line M12, D-coded, 1.0 m M12 plug straight - M12 plug straight drag chain suitable, 4-pole, green

P/N
142M1D11010
EAN 4250184139447
2019/01/08

Technical Data

Connections/interfaces

Cable sheath diameter (min. - max.)

Cable sheath diameter	6.5 mm
Cable sheath diameter	0.236 in.
acceleration	4 m/s ²

Electrical characteristics

Current carrying capacity	4
Rated voltage	250 V
UL rating (cable)	600 V
Through resistance	max. 5 mOhm
Insulation resistance	min. 100 mOhm

Mechanical characteristics

Bending radius without load	min. 49 mm
Maximum operating bending radius	26 mm
Maximum operating bending radius	1.024 in.
Maximum installation load	52 mm
Maximum installation load	2.047 in.
Number of alternating bending cycles	3 million bending cycles
Alternating bending radius	100 mm
velocity	4 m/s
acceleration	4 m/s ²
Shielding braid coverage	85 %
Installation method	PROFINET type C

Materials and material properties

Material - Conductor	Cu (copper)
Material - Cable jacket	PUR
Material - Inner cable jacket	FRNC, with an aluminized film
Material - Body interface 1	Plastics
Material - Body interface 2	Plastics
Material - Contact interface 1	CuZn (brass)
Material - Contact interface 2	CuZn (brass)
Material - Contact finish interface 1	Au (gold)
Material - Contact finish interface 2	Au (gold)

Data sheet

Connection line M12, D-coded, 1.0 m M12 plug straight - M12 plug straight drag chain suitable, 4-pole, green

P/N
142M1D11010
EAN 4250184139447
2019/01/08

Technical Data

Materials and material properties

Material - Contact carriers interface 1	Plastics
Material - Contact carriers interface 2	Plastics
Material - Union nut interface 1	CuZn (brass)
Material - Union nut interface 2	CuZn (brass)
Material - Union nut finish interface 1	Ni (nickel)
Material - Union nut finish interface 2	Ni (nickel)
Material - Pair shield	plastic film
Material - Pair shield finish	Al (Aluminium)
Material - Main shield	Cu (copper) braid
Material - Main shield finish	Sn (tin)
Flame retardancy	yes
Halogen free	yes
Oil resistance	yes
UV-resistance	yes

Environmental conditions

Temperature (min. - max.)	
Temperature - Operating Å°C	-30 °C - 90 °C
Temperature - Operating Å°F	-22 °F - 194 °F
Particulate ingress interface 1	IP6X when plugged in
Liquid ingress/immersion interface 1	IPX7 when plugged in
Particulate ingress interface 2	IP6X when plugged in
Liquid ingress/immersion interface 2	IPX7 when plugged in

The product meets the following standards

Generic cabling systems	
General requirements	DIN EN 50173-1
Common test methods for cables under fire conditions	
UNCE	R118
Test for vertical flame propagation for a single insulated wire or cable	IEC 60332-1-2
Measurement of smoke density of cables burning	DIN EN 61034

Data sheet

Page 5/6

Connection line M12, D-coded, 1.0 m M12 plug straight - M12 plug straight drag chain suitable, 4-pole, green

P/N

142M1D11010

EAN 4250184139447

2019/01/08

Technical Data

Classifications

ETIM 5.0	EC002599
ETIM 6.0	EC002599

Packing details

Type of packaging	1 pc(s) / plastic bag
Packaging unit - Weight (gram)	114 g
Packaging unit - Weight (pound)	0.25 lb

P | Cabling

Data sheet

Page 6/6

Connection line M12, D-coded, 1.0 m
M12 plug straight - M12 plug straight
drag chain suitable, 4-pole, green

P/N
 142M1D11010

EAN 4250184139447
 2019/01/08

Illustrations

Dimensional drawing

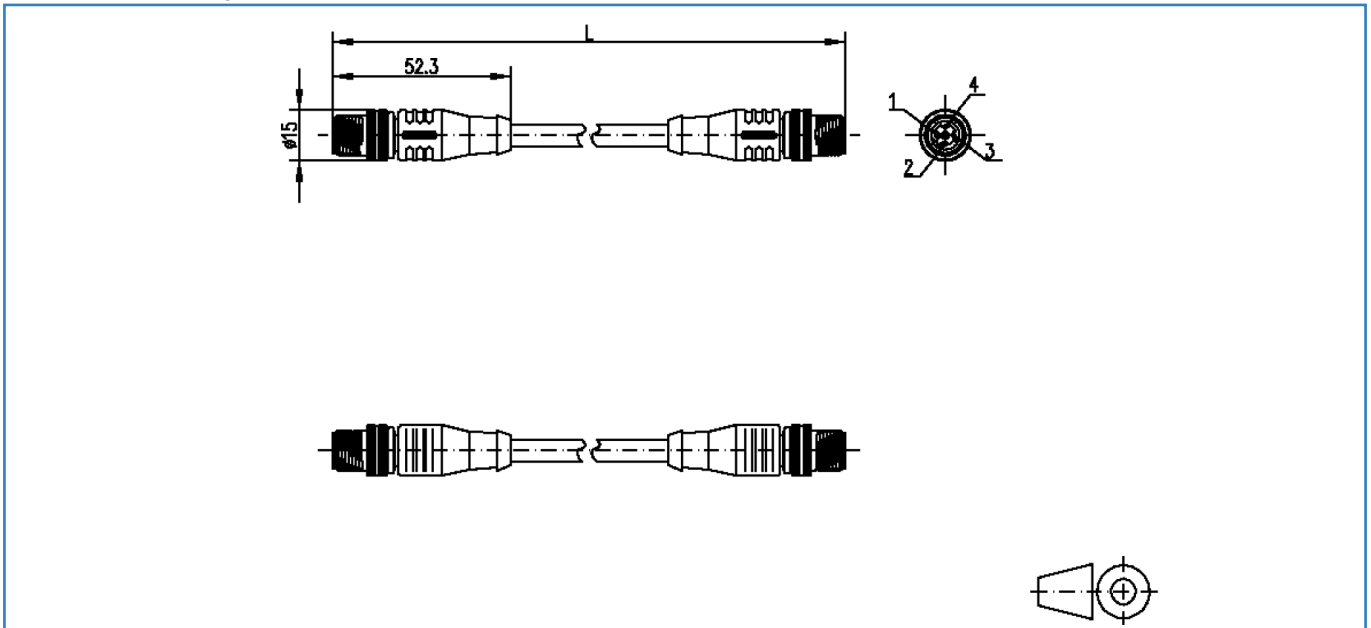

Wiring

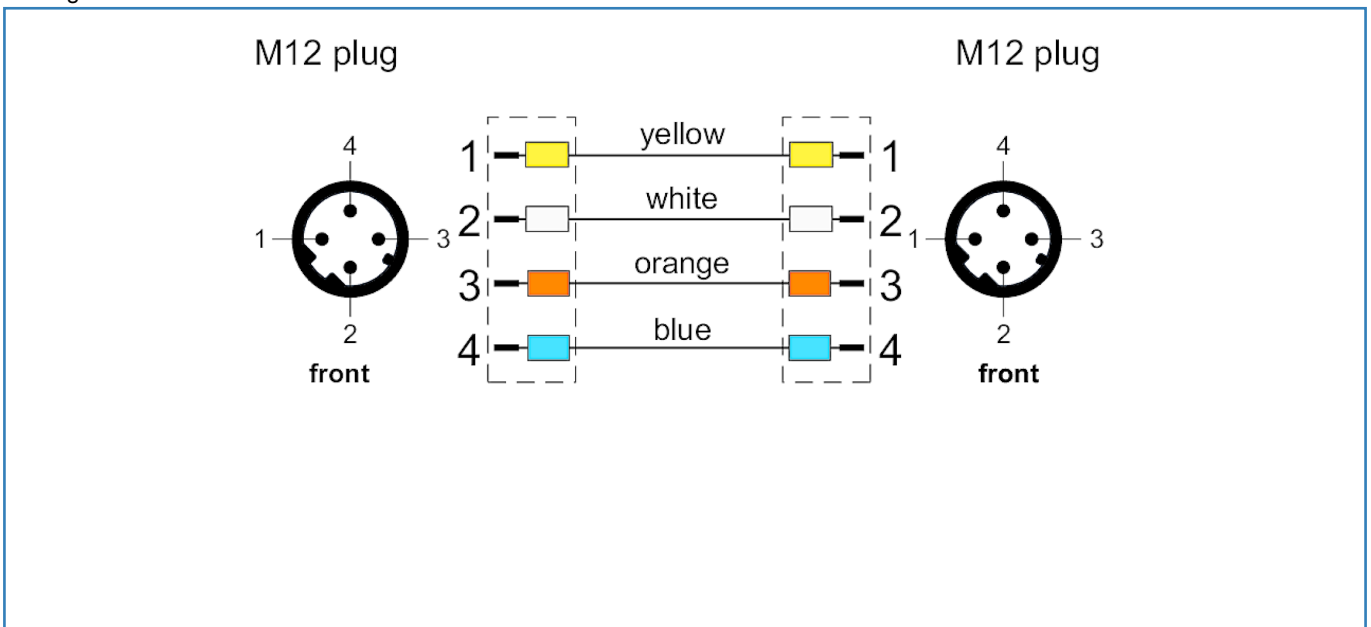

© 2019 METZ CONNECT - Technische Änderungen vorbehalten! Subject to modifications! Sous réserve de modifications techniques!