

Figure 1

### 1. INTRODUCTION

This instruction sheet provides termination procedures for shielded and grounded AMP 110Connect Panel Mount Jacks.

**NOTE** All dimensions are in millimeters [with inches in brackets]. Illustrations are for reference only and are not drawn to scale.

Reasons for reissue of this sheet are provided in Section 4, REVISION SUMMARY.

### 2. DESCRIPTION

The jacks accept four pair twisted-pair cable with 22 to 26 AWG solid conductors or 20 to 26 AWG stranded conductors. The maximum conductor insulator diameter is 1.27 mm [.050 in.].

### 3. TERMINATION

**NOTE** Wire termination requires the use of Impact Tool 569994-1, KRONE Universal Wire Insertion Tool, or stuffer cap.

1. Strip cable jacket back 50.8 mm [2.00 in.] as shown in Figure 2.
2. Fold metal foil back over cable jacket. Trim foil, leaving 9.52 mm [.375 in.] of foil over jacket.

3. Remove clear wrapping from twisted-pair wires.

**NOTE** Do NOT cut the drain wire.

**For Shielded Cable with Insulation Less than 6.1 [.24] Diameter**

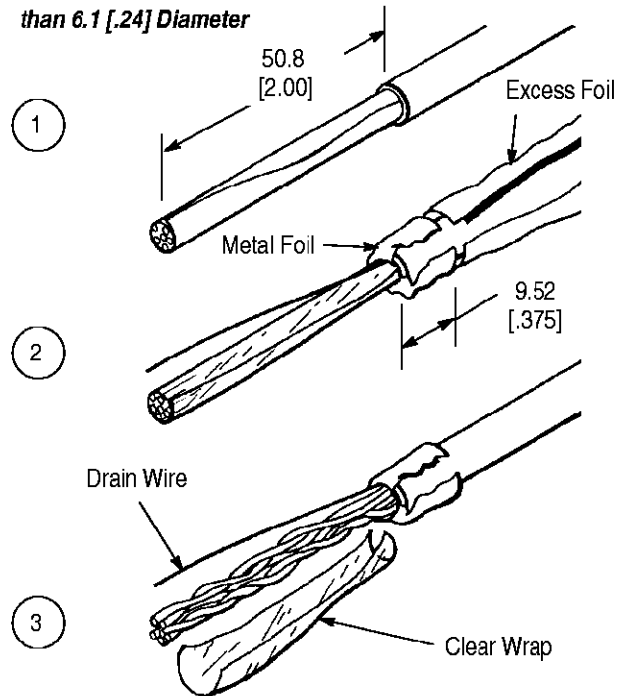

**NOTE:** Not to Scale

**Wire Dress for Shielded Cable with Insulation More than 6.1 [.24] Diameter and with Foil on Outside of Foil Lamination**

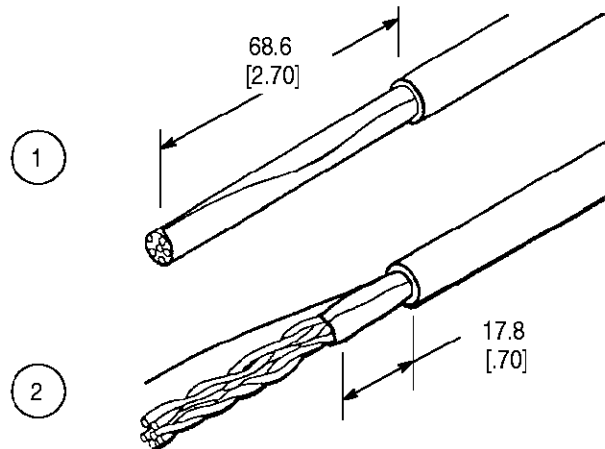

Figure 2

4. Align cable in ground clip – with open-side of foil facing out and end of cable jacket flush with top of clip. See Figure 3.

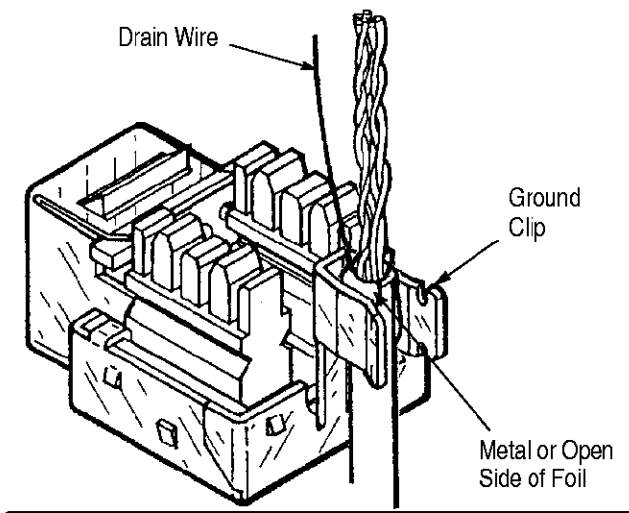

Figure 3

5. Using pliers, pinch tabs on ground clip around cable foil until tabs are parallel. See Figure 4.

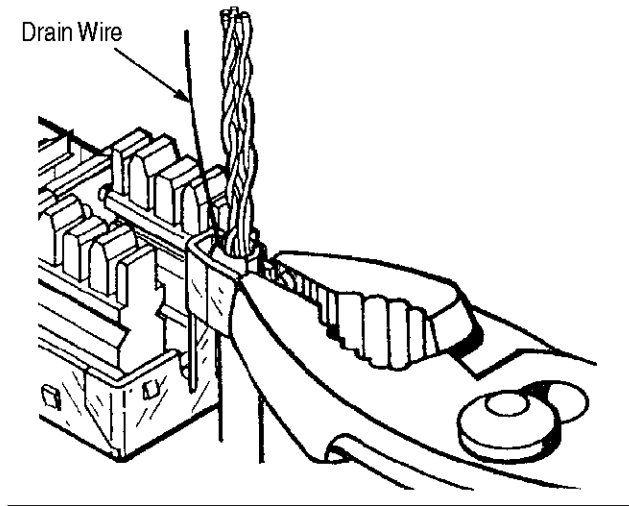

Figure 4

6. Grasp drain wire with needle-nose pliers. Bend wire around clip tabs in a figure-8 pattern, using slots provided in tabs. Use all of drain wire, and end with wire between tabs. Wrap 1 1/2 turns of 12.7-mm [.50-in.] wide vinyl electrical tape around ground clip. See Figure 5.

**CAUTION**

Exercise caution when installing heat shrink tubing. Excessive heat could damage the connector and wiring.

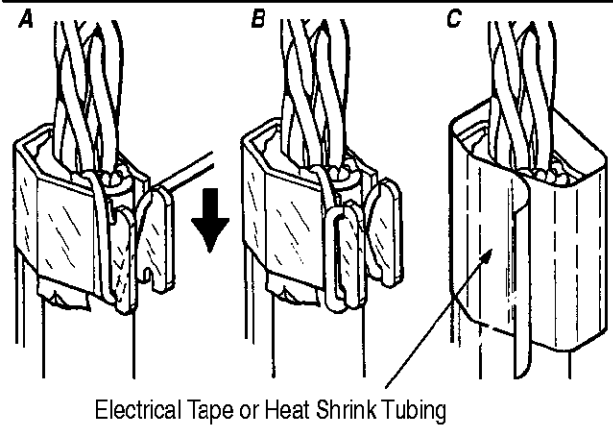

Figure 5

7. Bend conductors back at right angle to clip. Do NOT untwist pairs. Bend ground clip forward between blocks. See Figure 6.

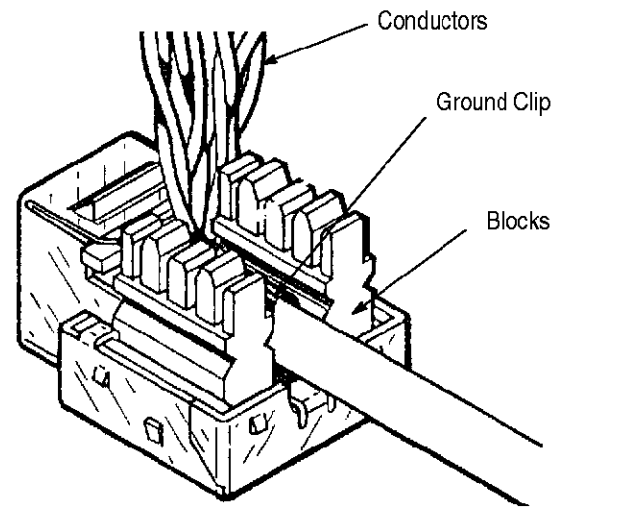

Figure 6

8. Pull orange pair and brown pair through openings on opposite sides. Bend wires around blocks and align them with appropriate color code slots (use minimum slack while maintaining twist). See Figure 7.

9. Use tool to punch wires down into slot and cut off excess wire. Remove loose wire pieces.

**CAUTION**

Set impact setting for low-impact. Orient tool so cutoff blade is on inside of block.

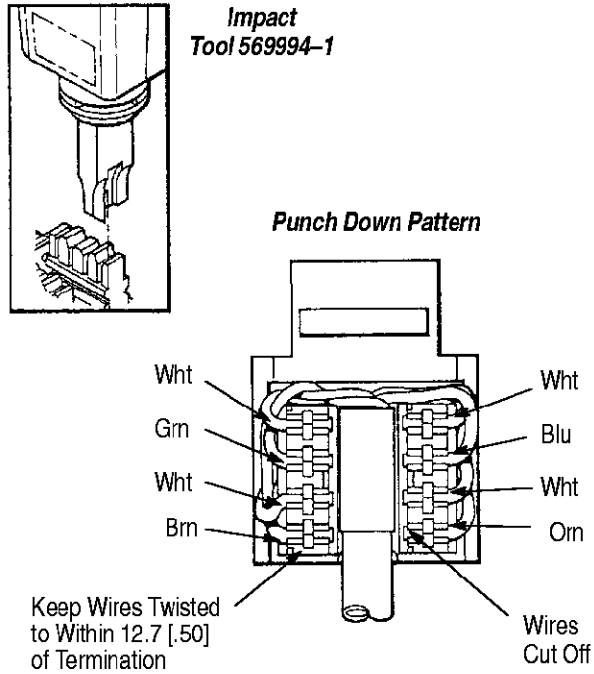

Figure 7

10. Repeat Steps 8 and 9 with blue pair and green pair.

11. Press conductors flat against blocks. For shielded applications, slide the top shield over the housing until it snaps in place. See Figure 8.

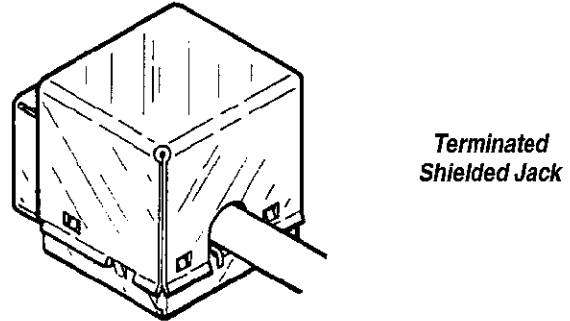

Figure 8

**4. REVISION SUMMARY**

Revisions to this document per EC 0990-0534-01:

- Updated document to corporate requirements
- Added [www.ampnetconnect.com](http://www.ampnetconnect.com) address